

TUBERÍA C/S PINTADA

UNE-EN 10255 ó UNE-EN 10217

DN TUBO	e (mm)	TUBERÍA PINTADA	
		EXTREMOS RANURADO	EXTREMOS LISOS
DN15	2,6	--	5,54 €
DN20	2,6	--	6,83 €
DN25	3,2	--	6,83 €
DN32	2,3	6,52 €	6,24 €
	2,6	7,29 €	7,01 €
	3,2	8,87 €	8,59 €
DN40	2,3	7,31 €	7,03 €
	2,6	8,25 €	7,97 €
	3,2	10,02 €	9,74 €
DN50	2,3	9,04 €	8,77 €
	2,6	10,16 €	9,88 €
	3,2	12,40 €	12,12 €
	3,6	13,87 €	13,59 €
DN65	2,6	12,71 €	12,43 €
	3,2	15,50 €	15,22 €
	3,6	17,33 €	17,05 €
DN80	2,9	16,15 €	15,87 €
	3,2	17,72 €	17,44 €
	4	21,94 €	21,66 €
DN100	3,2	22,59 €	22,31 €
	3,6	25,33 €	25,05 €
	4,5	30,56 €	30,28 €
DN125	3,6	31,14 €	30,86 €
	5	44,27 €	44,00 €
DN150	4	41,93 €	41,65 €
	4,5	47,01 €	46,73 €
DN200	4,5	60,22 €	59,94 €
	5	71,89 €	71,61 €
DN250	5	101,27 €	98,32 €
DN300	5,6	137,11 €	133,12 €

- Pintura: Granallado sa 2 ½" ó desengrasado y fosfatado. Pintura al horno poliéster RAL 3000. Otros RAL consultar.
- Clima.- Pintura líquida antioxidante gris RAL012.
- Portes pagados para camiones completos, otros casos consultar.

TUBERÍA PREFAB. con MANGUITO ROSCA HEMBRA

UNE-EN 10217 ó UNE-EN 10255

DN TUBO	EN 10217-1 e (mm)	MANGUITO DN15						MANGUITO DN20					
		1	2	3	4	5	6	1	2	3	4	5	6
DN32	2,3	7,02	7,60	8,27	8,98	9,74	10,50	7,06	7,68	8,32	9,05	9,84	10,63
	2,6	7,76	8,41	9,07	9,81	10,59	11,42	7,78	8,44	9,16	9,89	10,70	11,54
	2,9	8,49	9,16	9,86	10,62	11,42	12,29	8,52	9,19	9,93	10,70	11,53	12,42
	3,2	9,19	9,86	10,62	11,40	12,24	13,15	9,20	9,92	10,69	11,48	12,34	13,24
DN40	2,3	7,72	8,32	9,00	9,74	10,48	11,31	7,73	8,38	9,05	9,81	10,59	11,42
	2,6	8,54	9,20	9,92	10,66	11,47	12,31	8,57	9,25	9,96	10,74	11,55	12,43
	2,9	9,37	10,01	10,77	11,55	12,38	13,27	9,38	10,07	10,82	11,66	12,51	13,39
	3,2	10,14	10,82	11,60	12,43	13,29	14,22	10,15	10,88	11,68	12,53	13,39	14,33
DN50	2,3	9,26	9,95	10,69	11,47	12,29	13,17	9,27	9,99	10,74	11,54	12,38	13,27
	2,6	10,30	11,03	11,79	12,58	13,49	14,40	10,32	11,09	11,87	12,68	13,59	14,54
	3,2	13,88	14,71	15,52	16,45	17,39	18,44	13,89	14,74	15,58	16,53	17,50	18,56
	3,6	15,55	16,43	17,31	18,29	19,30	19,96	15,57	16,46	17,39	18,36	19,39	20,51
DN65	2,6	12,65	13,49	14,32	15,25	16,21	17,26	12,68	13,52	14,37	15,33	16,32	17,38
	3,2	15,25	16,14	17,12	18,17	19,25	20,39	15,26	16,18	17,20	18,24	19,36	20,51
	3,6	16,89	17,85	18,89	19,99	21,13	22,39	16,91	17,89	18,96	20,07	21,21	22,49
DN80	2,9	15,79	16,72	17,71	18,77	19,85	21,03	15,80	16,76	17,78	18,83	19,98	21,16
	3,2	17,20	18,17	19,19	20,33	21,49	22,74	17,23	18,22	19,30	20,39	21,58	22,86
	4,0	21,03	22,17	23,38	24,63	25,99	27,45	21,06	22,23	23,45	24,73	26,12	27,55

DN TUBO	EN 10217-1 e (mm)	MANGUITO DN25					
		1	2	3	4	5	6
DN32	2,3	7,72	8,52	9,37	10,26	11,35	11,75
	2,6	8,57	9,40	10,29	11,21	12,36	12,82
	2,9	9,42	10,26	11,18	12,16	13,34	13,82
	3,2	10,23	11,11	12,05	13,09	14,32	14,78
DN40	2,3	8,12	8,86	9,74	10,59	11,54	12,56
	2,6	8,98	9,79	10,66	11,55	12,56	13,60
	2,9	9,81	10,66	11,54	12,51	13,52	14,60
	3,2	10,63	11,51	12,42	13,39	14,44	15,59
DN50	2,3	9,38	10,19	11,03	11,94	12,90	13,97
	2,6	10,41	11,28	12,13	13,09	14,08	15,20
	3,2	14,00	14,91	15,89	16,92	18,04	19,23
	3,6	15,67	16,62	17,63	18,74	19,89	21,13
DN65	2,6	12,76	13,66	14,64	15,70	16,83	18,02
	3,2	15,35	16,39	17,46	18,64	19,83	21,16
	3,6	16,98	18,08	19,19	20,42	21,75	23,12
DN80	2,9	15,88	16,92	18,07	19,18	20,43	21,79
	3,2	17,28	18,38	19,52	20,76	22,08	23,46
	4,0	21,13	22,39	23,68	25,10	26,54	28,15

PRECIOS: € / ml.

MANGUITOS: Roscados aprobados FM.

TUBERÍA: A.C.S. UNE-EN10217 ó UNE-EN 10255(W)

LARGO: 2,00 m a 9,00 m. Extremos lisos o ranurados.

Nota. - Si fuese manguito rosca macho tendría un incremento de precio de 5% sobre el precio con manguito rosca hembra.

- Pintura: Granallado sa 2 ½" ó desengrasado y fosfatado. Pintura al horno poliéster RAL 3000. Otros RAL consultar.
- Clima.- Pintura líquida antioxidante gris RAL012.
- Portes pagados para camiones completos, otros casos consultar.

TUBERÍA PREFAB. con MANGUITO RANURADO

UNE-EN 10217 ó UNE-EN 10255

DN TUBO	EN 10217-1 e (mm)	MANGUITO DN32						MANGUITO DN40											
		1	2	3	4	5	6	1	2	3	4	5	6						
DN 50	2,3	10,59	12,12	13,76	15,55	17,42	19,44												
	2,6	11,87	13,29	14,93	16,72	18,66	20,72												
	3,2	14,45	16,18	18,12	20,30	22,72	25,46												
	3,6	16,16	18,09	20,28	22,71	25,43	28,48												
DN 65	2,6	14,27	15,95	17,70	19,56	21,57	23,74	14,69	16,45	18,31	20,36	22,50	24,85						
	3,2	17,13	19,18	21,47	24,07	26,94	30,18	17,30	19,37	21,69	24,30	27,21	30,44						
	3,6	18,55	167,77	23,27	26,06	29,19	29,76	18,74	20,99	23,51	26,31	29,48	33,01						
DN 80	2,9	17,90	19,70	21,67	23,82	26,21	28,84	18,08	19,89	21,89	24,07	26,47	29,12						
	3,2	19,64	21,61	23,77	26,13	28,75	31,64	19,83	21,82	24,00	26,40	29,04	31,94						
	4,0	22,86	25,15	27,67	30,43	33,47	36,81	23,09	25,40	27,93	30,72	33,80	37,18						
DN 100	3,2	24,43	26,34	28,38	30,59	32,93	35,35	24,69	27,13	29,85	32,84	36,13	39,73						
	3,6	27,38	29,58	31,94	34,50	37,26	40,24	27,67	30,43	33,47	36,81	40,50	44,54						
	4,5	33,01	35,66	38,81	41,59	44,92	48,51	33,34	36,68	40,35	44,38	48,81	53,70						

DN TUBO	EN 10217-1 e (mm)	MANGUITO DN50						MANGUITO DN65						MANGUITO DN80						
		1	2	3	4	5	6	1	2	3	4	5	6	1	2	3	4	5	6	
DN 80	2,9	18,59	20,69	22,87	25,25	27,81	30,53													
	3,2	20,13	22,26	24,55	26,94	29,59	32,37													
	4,0	24,24	26,49	28,90	31,49	34,26	37,22													
DN 100	3,2	24,77	27,26	29,98	32,97	36,27	39,90	25,79	28,52	31,49	34,65	38,03	41,67							
	3,6	27,74	30,51	33,56	36,93	40,61	44,68	28,46	31,31	34,43	37,62	41,10	44,82							
	4,5	33,43	36,76	40,46	44,50	48,94	53,83	33,99	37,38	40,73	44,40	48,41	52,32							
DN 150	4,0	42,66	46,90	48,39	51,52	54,87	58,44	43,22	46,42	49,84	53,54	57,51	61,75	44,92	48,51	52,41	56,60	61,12	66,00	
	4,5	47,27	50,41	53,70	57,21	60,94	64,94	47,70	51,19	54,95	58,91	63,20	67,73	49,62	53,59	57,89	62,52	67,52	72,91	
DN 200	4,5							60,53	64,54	68,80	73,32	78,17	83,31	61,33	66,22	71,41	76,91	82,83	89,19	
	6,3							81,99	86,84	91,95	97,45	103,20	109,36	82,69	88,46	94,51	100,98	107,82	115,11	

PRECIOS: € / ml.
 MANGUITOS: Ranurados aprobados FM.
 TUBERÍA: A.C.S. UNE-EN10217 ó UNE-EN 10255(w)
 LARGO: 2,00 m a 9,00 m. Extremos lisos o ranurados.

Nota. - Si fuese manguito rosca macho tendría un incremento de precio de 5% sobre el precio con manguito rosca hembra.

- Pintura: Granallado sa 2 ½" ó desengrasado y fosfatado. Pintura al horno poliéster RAL 3000. Otros RAL consultar.
- Clima.- Pintura líquida antioxidante gris RAL012.
- Portes pagados para camiones completos, otros casos consultar.

REDUCCIONES EXCÉNTRICAS <15°

EXTREMOS LISOS / EMBRIDADOS / RANURADOS

DN	EXTREMOS LISOS	EXTREMOS RANURADOS	EXTREMOS EMBRIDADOS
DN65 x DN50	Consultar	Consultar	Consultar
	(155mm.)	(315mm.)	(245mm.)
DN80 x DN65	Consultar	Consultar	Consultar
	(178mm.)	(338mm.)	(273mm.)
DN100 x DN80	Consultar	Consultar	Consultar
	(230mm.)	(390mm.)	(332mm.)
DN150 x DN80	Consultar	Consultar	Consultar
	(340mm.)	(500mm.)	(445mm.)
DN150 x DN100	Consultar	Consultar	Consultar
	(340mm.)	(500mm.)	(447mm.)
DN200 x DN100	Consultar	Consultar	Consultar
	(440mm.)	(600mm.)	(554mm.)
DN200 x DN125	Consultar	Consultar	Consultar
	(440mm.)	(600mm.)	(557mm.)
DN200 x DN150	Consultar	Consultar	Consultar
	(440mm.)	(600mm.)	(557mm.)
DN250 x DN100	Consultar	Consultar	Consultar
	(625mm.)	(785mm.)	(747mm.)
DN250 x DN125	Consultar	Consultar	Consultar
	(550mm.)	(710mm.)	(675mm.)



Fabricadas en chapa de acero al carbono calidad ST-37.
 Espesor 3,0mm., hasta DN150; 4,0mm hasta DN250 y 5,0mm para superiores.
 Los precios incluyen acabado pintado rojo RAL3000. Consulte otros diámetros y longitudes.

VELAS REDUCIDAS POR EXTRUSIÓN

PINTADAS / GALVANIZADAS

PRECIOS NETOS VELAS EXTRUSIONADAS, PINTADAS O GALVANIZADAS						
Longitud / \varnothing	$\varnothing 1'' - 3/4''$	$\varnothing 1'' - 1/2''$	$\varnothing 1 1/4'' - 1''$	$\varnothing 1 1/4'' - 3/4''$	$\varnothing 1 1/4'' - 1/2''$	$\varnothing 1 1/2'' - 1 1/4''$
l < 200 mm	12,70 €	12,70 €	15,01 €	17,55 €	20,05 €	17,15 €
200 ≤ l < 300 mm	13,52 €	13,52 €	15,94 €	18,56 €	21,22 €	18,24 €
300 ≤ l < 400 mm	14,24 €	14,24 €	16,81 €	19,58 €	22,42 €	19,23 €
400 ≤ l < 500 mm	14,99 €	14,99 €	17,67 €	20,63 €	23,56 €	20,21 €
500 ≤ l < 600 mm	15,74 €	15,74 €	18,54 €	21,68 €	24,73 €	21,22 €
600 ≤ l < 700 mm	16,46 €	16,46 €	19,43 €	22,70 €	25,94 €	22,23 €
700 ≤ l < 800 mm	17,27 €	17,27 €	20,37 €	23,74 €	27,13 €	23,27 €
800 ≤ l < 900 mm	17,99 €	17,99 €	21,22 €	24,73 €	28,27 €	24,31 €
900 ≤ l < 1000 mm	18,74 €	18,74 €	22,11 €	25,77 €	29,46 €	25,28 €
1000 ≤ l < 2000 mm	19,48 €	19,48 €	22,98 €	26,80 €	30,64 €	26,28 €
2000 ≤ l < 3000 mm	21,00 €	21,00 €	24,76 €	28,90 €	33,03 €	28,33 €
3000 ≤ l < 4000 mm	22,47 €	22,47 €	26,52 €	30,93 €	35,37 €	30,34 €
4000 ≤ l < 5000 mm	23,96 €	23,96 €	28,27 €	33,03 €	37,74 €	32,34 €
5000 ≤ l < 6000 mm	25,51 €	25,51 €	30,05 €	35,07 €	40,08 €	34,41 €

PRECIOS NETOS VELAS EXTRUSIONADAS, PINTADAS O GALVANIZADAS					
Longitud / \varnothing	$\varnothing 1 1/2'' - 1''$	$\varnothing 1 1/2'' - 3/4''$	$\varnothing 2'' - 1 1/2''$	$\varnothing 2'' - 1 1/4''$	$\varnothing 2'' - 1''$
l < 200 mm	20,05 €	22,93 €	19,76 €	23,04 €	26,34 €
200 ≤ l < 300 mm	21,22 €	24,31 €	20,89 €	24,40 €	27,88 €
300 ≤ l < 400 mm	22,42 €	25,60 €	22,09 €	25,77 €	29,40 €
400 ≤ l < 500 mm	23,59 €	26,96 €	23,23 €	27,10 €	30,99 €
500 ≤ l < 600 mm	24,82 €	28,32 €	24,40 €	28,46 €	32,52 €
600 ≤ l < 700 mm	25,94 €	29,69 €	25,54 €	29,80 €	34,06 €
700 ≤ l < 800 mm	27,13 €	30,99 €	26,74 €	31,17 €	35,59 €
800 ≤ l < 900 mm	28,32 €	32,36 €	27,88 €	32,52 €	37,18 €
900 ≤ l < 1000 mm	29,51 €	33,71 €	29,07 €	33,90 €	38,70 €
1000 ≤ l < 2000 mm	30,70 €	35,07 €	30,20 €	35,26 €	40,25 €
2000 ≤ l < 3000 mm	33,03 €	37,74 €	32,52 €	37,91 €	43,36 €
3000 ≤ l < 4000 mm	35,40 €	40,48 €	34,83 €	40,64 €	46,43 €
4000 ≤ l < 5000 mm	37,74 €	43,14 €	37,18 €	43,36 €	49,55 €
5000 ≤ l < 6000 mm	40,13 €	45,85 €	39,50 €	46,10 €	52,67 €

Fabricadas extrusionadas y pintadas
Los precios incluyen acabado pintado o galvanizado

WWW.FIREPIPING.COM

PUNTOS DE VACIADO Y PRUEBAS PARA DRENAJES / LIMPIEZA / CALIBRACIÓN

PUNTOS DE VACIADO	PRECIO UD
DN25	77,04 €
DN32	84,89 €
DN40	92,85 €
DN50	115,38 €

PUNTOS DE PRUEBA Y DRENAJE	PRECIO UD
DN40 x DN25	184,90 €
DN50 x DN40	258,53 €
DN65 x DN40	312,62 €

DISCO CALBRADO	PRECIO UD
K-80	17,65 €
K-115	17,65 €
K-160	17,65 €
K-200	17,65 €
K-242	17,65 €
K-320	17,65 €
K-363	17,65 €

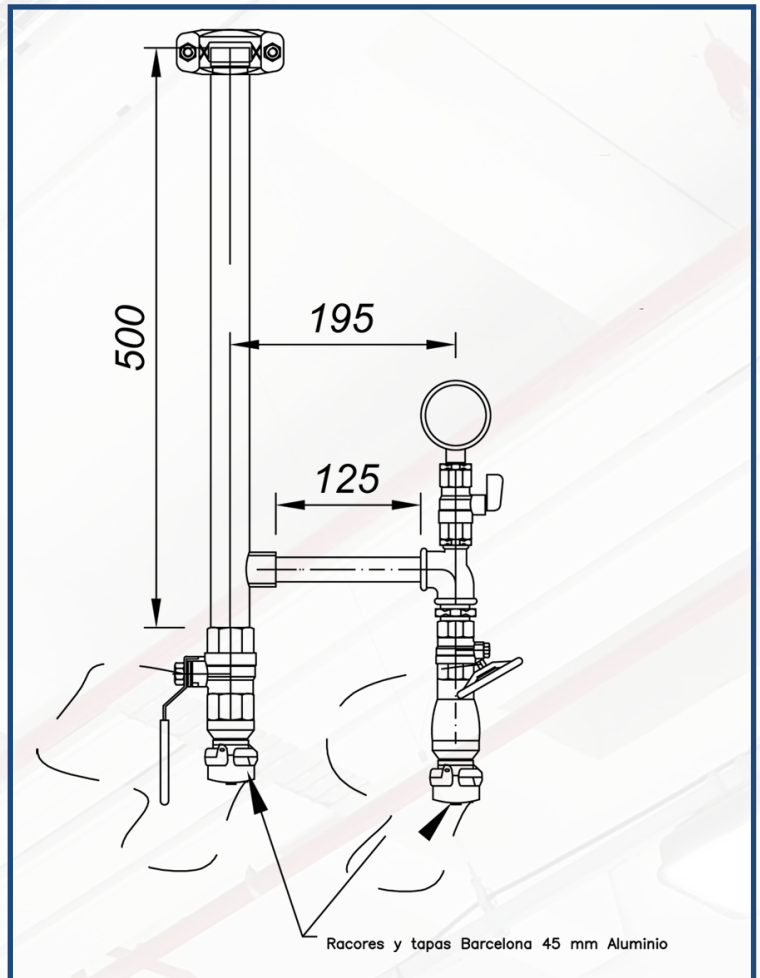

Punto de prueba y limpieza DN40 MOD. EFP	
Material	Cantidad
Válvula de asiento inclinado en latón 1" H-H	1
Válvula de esfera de 1 ½" latón cromado H-H	1
Junta ranurada rígida 1 ½"	1
Tubería 10255 1 ½"	1
Tubería 10255 1"	1
Manguito reducido M/H 1 ½" X 1" fig. 246 galv	1
Machón rosca doble fig. 280 1" galva	1
Tuerca reducción ½" M x 1/4" H fig. 241 galv	1
Racor Barcelona 45 mm aluminio	2
Tapón Barcelona 45 mm aluminio	2
Manguito 1"	1
Te reducida de 1" x 1" x 1/2" fig. 130	1
Mini válvula M/H 1/4"	1
Manómetro 1/4" 0-16 bar	1

FILTROS en T y PRODUCTOS ESPECIALES

PINTADAS / GALVANIZADAS

FILTROS T PARA PETROQUÍMICA	PRECIO
Mod. eFP de 2"	363,02 €
Mod. eFP de 3"	488,45 €
Mod. eFP de 4"	740,12 €
Mod. eFP de 6"	1.135,19 €
Mod. eFP de 8"	1.449,06 €
Mod. eFP de 10"	2.181,65 €
Mod. eFP de 12"	3.408,76 €
Mod. eFP de 14"	4.624,29 €



PLACA DE RETENCIÓN DE CALOR	PRECIO UD
Placa Retención de calor Mod. eFP	144,03 €

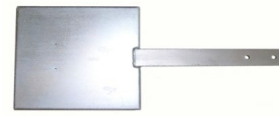

PRODUCTO	DESCRIPCIÓN	PINTADO	GALVANIZADO
	COLECTORES PUESTOS DE CONTROL	CONSULTAR	CONSULTAR
	RAMALES CURVADOS REDUCIDOS POR EXTRUSIÓN	CONSULTAR	CONSULTAR
	CODOS ESPECIALES DE DISTINTOS ÁNGULOS	CONSULTAR	CONSULTAR
	CARRETES EMBRIDADOS, RANURADOS... ASPIRACIONES	CONSULTAR	CONSULTAR
	FABRICACIONES EN INOXIDABLES	CONSULTAR	CONSULTAR